



APLAST
ROTOMOULDING
PIPING | TOOLING



AFLEX PIPES FOR PROTECTION





AFLEX PIPES FOR PROTECTION

USAGE AND DESCRIPTION:

Cable sewerage AFLEX with double walls is made of high density polyethylene intended to protect the cables, pipes etc. in the following applications:

- **Electrical distribution:** high and low voltage lines,
- **Telecommunications:** optical cables, TV-multimedia lines,
- **Road signs,**
- **Railway systems,**
- **Protection of water supply and other types of pipes,**
- **Road culverts ...**

It consists of two tubular elements, mutually coextruded, an external ribbed element (due to greater resistance to surface pressure, extreme lightness and flexibility), and an internal smooth element (for the smooth insertion of cables).

ADVANTAGES:

- Resistant to chemicals.
- No special preparation of trenches needed for the installation of pipes.
- The flexibility of the pipe allows for an easy installation in all terrains and configurations.
- Easy to avoid obstacles without the use of bows and similar devices.
- Absorbs dents caused by stones or other types of impact, without affecting the applicability.
- Suitable for installation in wet, damp and aggressive terrains.
- The lightness of the pipe facilitates the storage, transportation and installation.
- To connect two pipes a simple coupler is used.

FEATURES:

- Pipes are manufactured in different standard colours:

red – energetics,



yellow – telecommunications,

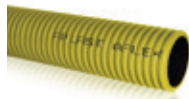

green – optics,



black with longitudinal red stripes - energetics,



blue - water supply,



black or black with longitudinal stripes to highlight the function.



- Different colours of the pipes are possible (for previously agreed quantities).
- AFLEX pipes are manufactured in standard lengths in coils of 50 m with wire for retraction (\varnothing 40 to 110 mm), or in bars at 6 m (\varnothing 110 mm), completed with a singular coupler.
- AFLEX pipes with double walls are manufactured according to the standard SIST EN ISO 61386-24. The resistance to shock is up to -25°C .
- The pipe material is stable at temperatures ranging from -50°C to $+90^{\circ}\text{C}$ without modification of the basic features. Electrical insulation resistance is greater than $100\text{ M}\Omega$.
- The electrical resistance is greater than 800 kV/cm .

TABLE 1:

Outer nominal diameter of the pipe d_e	Inner declared diameter of the pipe d_i	Type of packaging
40	33	Coil (50 m)
50	40	Coil (50 m)
63	52	Coil (50 m)
75	61	Coil (50 m)
90	77	Coil (50 m)
110	92	Coil (50 m) / Bars (6 m)

The internal diameter of the pipe d_i is determined by the standard SIST EN ISO 3126.

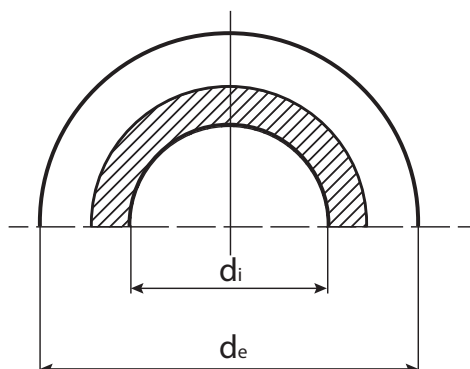

BACKFILLING THE EXCAVATION:

Backfilling the excavation is a very important procedure in the execution of cable sewerage, and it has to be carried out as shown in the sketch, which allows for the sewerage to respond to possible deformations of the terrain. The first layer comprises a suitable backfill material so that it covers the pipe completely.

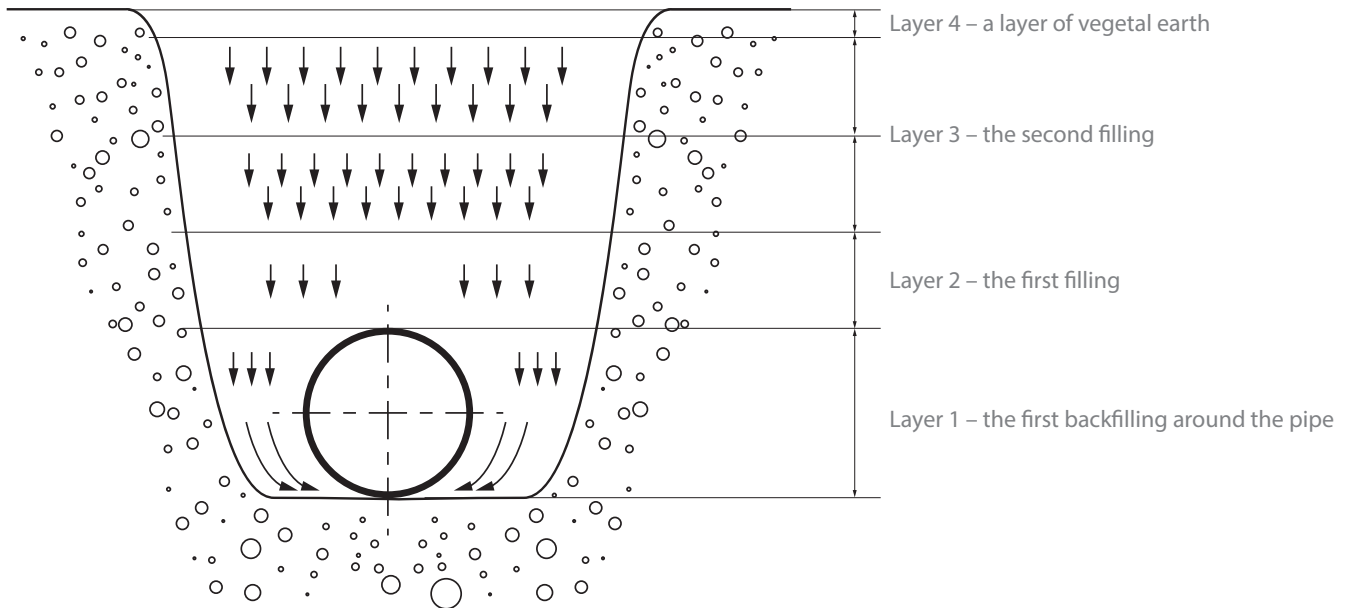

APLAST proizvodnja in trgovina d.o.o.
Petrovče 115a, 3301 Petrovče, Slovenia
T: +386 (0)3 713 24 50 | F: +386 (0)3 713 24 54
www.aplast.si | info@aplast.si



YOUR RETAILER: